

Visualizing Quality Control with Manhattan Mounts

Universal Ultra-Slim LCD Full-Motion Large-Screen Wall Mount

Model #461313

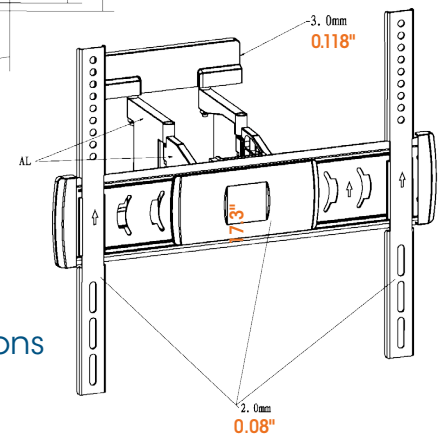
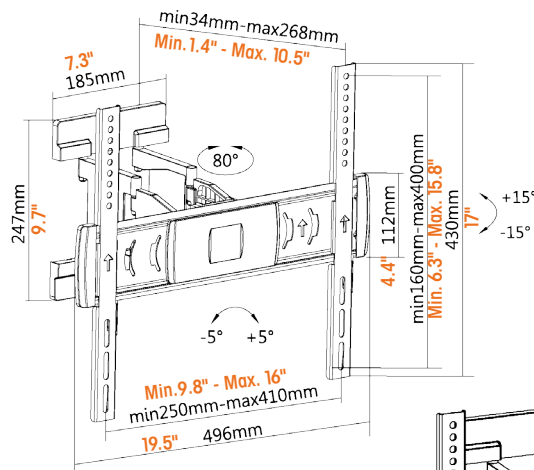
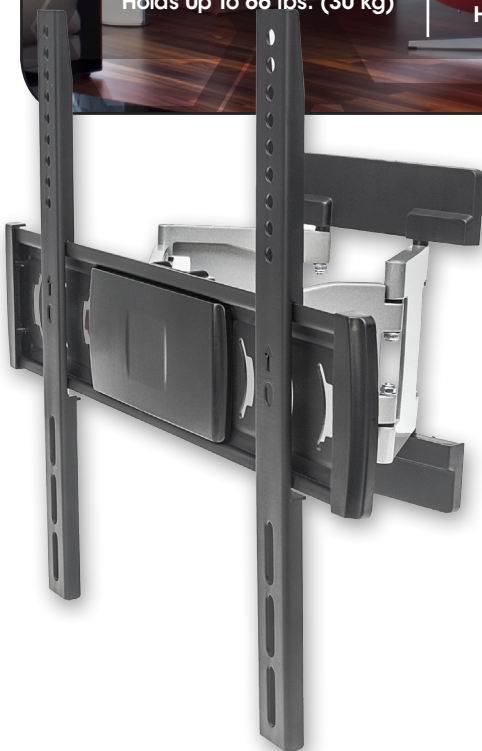

- Designed for flat-panel or curved televisions
- Easy installation ideal for home, office and commercial applications
- Meets VESA standards: 300x300, 400x200, 400x400



For more information, visit
manhattanproducts.com